

DIESEL ENGINE-GENERATOR SET

180-JC6DT3

180 ekW / 60 Hz / Standby
160 ekW / 60 Hz / Prime
208 - 600V



SYSTEM RATINGS

Standby

Voltage (L-L)	240V**	240V**	208V**	240V**	480V**	600V**
Phase	1	1	3	3	3	3
PF	1.0	1.0	0.8	0.8	0.8	0.8
Hz	60	60	60	60	60	60
kW	180	180	180	180	180	180
kVA	180	180	225	225	225	225
AMPS	750	750	625	541	271	217
skVA@30%						
Voltage Dip	267	370	370	370	370	378
Generator Model*	432CSL6210	432PSL6228	431CSL6206	431CSL6206	431CSL6204	431PSL6242
Temp Rise	130°C/27°C	130°C/27°C	130°C/27°C	130°C/27°C	130°C/27°C	125°C/40°C
Connection	12 LEAD ZIG-ZAG	4 LEAD	12 LEAD LOW WYE	12 LEAD HI DELTA	12 LEAD HI WYE	4 LEAD WYE

Prime

Voltage (L-L)	240V	240V	208V	240V	480V	600V
Phase	1	1	3	3	3	3
PF	1.0	1.0	0.8	0.8	0.8	0.8
Hz	60	60	60	60	60	60
kW	160	160	160	160	160	160
kVA	160	160	200	200	200	200
AMPS	667	667	555	481	241	192
skVA@30%						
Voltage Dip	267	370	370	370	370	378
Generator Model*	432CSL6210	432PSL6228	431CSL6206	431CSL6206	431CSL6204	431PSL6242
Temp Rise	105°C/40°C	105°C/40°C	105°C/40°C	105°C/40°C	105°C/40°C	105°C/40°C
Connection	12 LEAD ZIG-ZAG	4 LEAD	12 LEAD LOW WYE	12 LEAD HI DELTA	12 LEAD HI WYE	4 LEAD WYE

* The Generator Model Number identified in the table is for standard C Series Configuration. Consult the factory for alternate configuration.

** UL2200 Offered

FACTS

- // EPA Tier 3 Certified
- // Engine-Generator Set Tested to ISO 8528-5 for Transient Response
- // UL2200, CSA Listing Offered
- // Accepts Rated Load in One Step Per NFPA 110, Level 1
- // All engine-generator sets are prototype and factory tested
- // MTU Onsite Energy is a single source supplier
- // Global Product Support
- // 2 Year Standard Warranty
- // Custom Design for Any Application
- // 6068HF485 Diesel Engine
 - 6.8 Liter Displacement
 - Electronic Unit Pump Injection
 - 4-Cycle
- // Complete Range of Accessories
- // Permanent Magnet Generator (PMG) - Optional
 - Brushless, Rotating Field
 - 300% Short Circuit Capability
 - 2/3 Pitch Windings
- // Digital Control Panel(s)
 - UL Recognized, c  us, NFPA 110
 - Complete System Metering
 - LCD Display
- // Cooling System
 - Integral Set-Mounted
 - Engine Driven Fan

STANDARD EQUIPMENT

// Engine

.....
Air Cleaners

.....
Oil Pump

.....
Full Flow Oil Filter

.....
Jacket Water Pump

.....
Inter Cooler Water Pump

.....
Thermostat

.....
Exhaust Manifold - Dry

.....
Blower Fan & Fan Drive

.....
Radiator - Unit Mounted

.....
Electric Starting Motor - 12V

.....
Governor - Electric Isochronous

.....
Base - Formed Steel

.....
SAE Flywheel & Bell Housing

.....
Charging Alternator - 12V

.....
Battery Box & Cables

.....
Flexible Fuel Connectors

.....
Flexible Exhaust Connection

.....
EPA Certified Engine

// Generator

.....
NEMA MG1, IEEE and ANSI standards compliance for temperature rise and motor starting

.....
Sustained short circuit current of up to 300% of the rated current for up to 10 seconds

.....
Self-Ventilated and Drip-Proof

.....
Superior Voltage Waveform

.....
Digital, Solid State, Volts-per-Hertz Regulator

.....
No Load to Full Load Regulation

.....
Brushless Alternator with Brushless Pilot Exciter

.....
4 Pole, Rotating Field

.....
130°C Standby Temperature Rise

.....
1 Bearing, Sealed

.....
Flexible Coupling

.....
Full Amortisseur Windings

.....
125% Rotor Balancing

.....
3-Phase Voltage Sensing

.....
±1% Voltage Regulation

.....
100% of Rated Load - One Step

.....
3% Maximum Harmonic Content

// Digital Control Panel(s)

.....
Digital Metering

.....
Engine Parameters

.....
Generator Protection Functions

.....
Engine Protection

.....
SAE J1939 Engine ECU Communications

.....
Windows-Based Software

.....
Multilingual Capability

.....
Remote Communications to our RDP-110 Remote Annunciator

.....
16 Programmable Contact Inputs

.....
7 Contact Outputs

.....
UL Recognized, c  us, CE Approved

.....
Event Recording

.....
IP 54 Front Panel Rating with Integrated Gasket

.....
NFPA110 Level Compatible

APPLICATION DATA

// Engine

Manufacturer	John Deere
Model	6068HF485
Type	4-Cycle
Arrangement	6-Inline
Displacement: Cu In (lit)	415 (6.8)
Bore: in (cm)	4.2 (10.6)
Stroke: in (cm)	5 (12.7)
Compression Ratio	17:1
Rated RPM	1,800
Engine Governor	JDEC
Max Power: Standby: bhp (kWm)	315 (235)
Max Power: Prime: bhp (kWm)	286 (214)
Regulation	± 25%
Frequency	60 Hz
Air Cleaner	Dry

// Liquid Capacity (Lubrication)

Total Oil System: gal (lit)	8.5 (32.2)
Engine Jacket Water Capacity: gal (lit)	3.3 (11.9)
System Coolant Capacity: gal (lit)	7.75 (29.3)

// Electrical

Electric Volts DC	12
Cold Cranking Amps Under 0°F (-17.8°C)	800

// Fuel System

Fuel Supply Connection Size	3/8" NPT
Fuel Return Connection Size	3/8" NPT
Maximum Fuel Lift: ft (m)	6.7 (2)
Recommended Fuel	Diesel #2
Total Fuel Flow: gal/hr (lit/hr)	24.5 (93)

// Fuel Consumption

	STANDBY	PRIME
At 100% of Power Rating: gal/hr (lit/hr)	15.5 (58.6)	13.5 (51.9)
At 75% of Power Rating: gal/hr (lit/hr)	11.3 (42.9)	10.7 (40.5)
At 50% of Power Rating: gal/hr (lit/hr)	7.9 (30)	7.3 (27.6)

// Cooling - Radiator System

	STANDBY	PRIME
Ambient Capacity of Radiator: °F (°C)	122 (50)	122 (50)
Max. Restriction of Cooling Air, Intake, and Discharge Side of Rad.: in. H ₂ O (kPa)	0.5 (0.12)	0.5 (0.12)
Water Pump Capacity: gpm (lit/min)	70 (265)	70 (265)
Heat Rejection to Coolant: BTUM (kW)	5,404 (94.9)	4,766 (83.7)
Heat Rejection to Air to Air: BTUM (kW)	3,264 (57)	2,298 (40)
Heat Radiated to Ambient: BTUM (kW)	1,686 (29.7)	1,378 (24.2)

// Air Requirements

	STANDBY	PRIME
Aspirating: *SCFM (m ³ /min)	619 (17.5)	520 (14.7)
Air Flow Required for Rad. Cooled Unit: *SCFM (m ³ /min)	17,712 (502)	17,712 (502)
Air Flow Required for Heat Exchanger/Remote Rad. based on 25°F Rise: *SCFM (m ³ /min)	3,803 (108)	3,108 (89)

* Air density = 0.0739 lbm/ft³ (1.184 kg/m³)

// Exhaust System

	STANDBY	PRIME
Gas Temp. (Stack): °F (°C)	905 (485)	982 (528)
Gas Volume at Stack Temp: CFM (m ³ /min)	1,514 (42.9)	1,371 (38.8)
Maximum Allowable Back Pressure: in. H ₂ O (kPa)	40 (10)	40 (10)

WEIGHTS AND DIMENSIONS

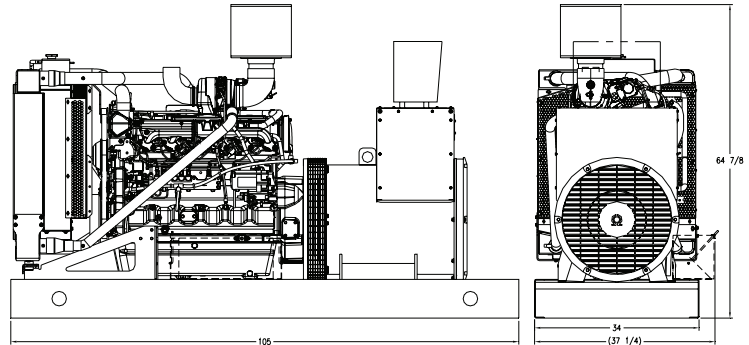

Drawing above for illustration purposes only, based on standard open power 480 volt generator. Lengths may vary with other voltages. Do not use for installation design.

System	Dimensions (L x W x H)	Weight (less tank)
OPU	105 x 37.25 x 64.9 in (2,670 x 950 x 1,650 mm)	3,420 lb (1,551 kg)

Weights and dimensions are based on open power units and are estimates only. Consult the factory for accurate weights and dimensions for your specific generator set.

SOUND DATA

Unit Type	Standby Full Load	Standby No Load	Prime Full Load	Prime No Load
OPU w/Critical Grade Muffler (dBA)	92.5	85	91	85
Sound Attenuated Enclosure (dBA)	84.5	77	83	77

Measurements for sound data are taken at 23 ft (7 m).

EMISSIONS DATA

NO _x + NMHC	CO	PM
2.76	0.43	0.059

All units are in g/hp-hr and are EPA D2 cycle values.

Emission levels of the engine may vary as a function of ambient temperature, barometric pressure, humidity, fuel type and quality, installation parameters, measuring instrumentation, etc. The data provided are laboratory results from one engine representing this rating. The data was obtained under controlled environmental conditions with calibrated instrumentation traceable to the United States National Bureau of Standards and in compliance with US EPA regulations found within 40 CFR Part 89. The weighted cycle value from each engine is guaranteed to be below the US EPA Standards at the US EPA defined conditions.

Materials and specifications subject to change without notice.

RATING DEFINITIONS AND CONDITIONS

- // Ambient capability factor at 984 ft (300 m). Consult your local MTU Onsite Energy Power Generation Distributor for other altitudes.
- // Standby ratings apply to installations served by a reliable utility source. The standby rating is applicable to varying loads for the duration of a power outage. No overload capability for this rating. Ratings are in accordance with ISO-3046/1, BS 5514, AS 2789, and DIN 6271.
- // Prime power ratings apply to installations where utility power is unavailable or unreliable. At varying load, the number of generator set operating hours is unlimited. A 10% overload capacity is available for one hour in twelve. Ratings are in accordance with ISO-8528/1, overload power in accordance with ISO-3046/1, BS 5514, AS 2789, and DIN 6271. For limited running time and base load ratings, consult the factory.
- // Deration Factor:
 - Altitude:** 0.5% per 1,000 ft (305 m) above 5,000 ft (1,524 m) and 4% per 1,000 ft (305 m) above 10,000 ft (3,048 m).
 - Temperature:** 0.5% per 10°F (5.5°C) above 77°F (25°C).